

5.125" (130 mm) PP DF, PN 51422

PP – POWER PORT, DF – DEBRIS FREE

EXPLODED VIEW

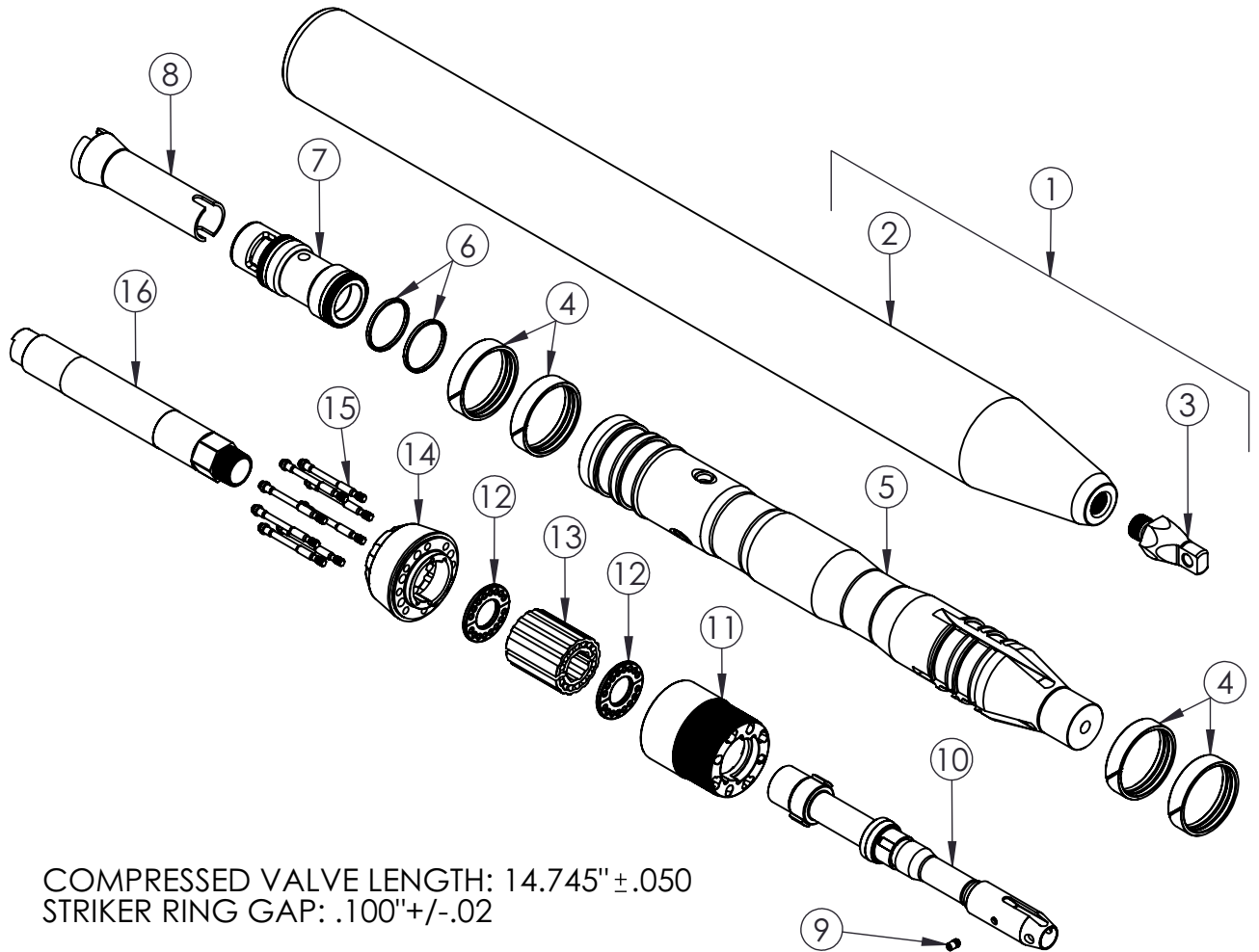

5.125" (130 mm) PP DF, PN 51422

HAMMERHEAD®

5.125" (130 mm) PP DF, PN 51422

PP – POWER PORT, DF – DEBRIS FREE

PARTS LIST

ITEM	PART NUMBER	DESCRIPTION	QTY.	REMARKS
1	51435	BODY ASSEMBLY 5.125" PP	1	INCLUDES ITEMS 2, 3 & 20-22
3	51402	PLUG-TAPERED	1	ANTI-SEEZ & TORQUE TO 400FT-LB (LEFT HAND THREAD)
4	51210	STRIKER RING, 5.125"	4	
5	51409	5.125" PP STRIKER	1	
6	51423	VALVE RING REPLACEMENT KIT, 5.125"	1	INCLUDES TWO RINGS & COMPRESSOR
7	51424	VALVE REPLACEMENT KIT, 5.125"	1	INCLUDES VALVE, RINGS & COMPRESSOR
8	51410	CONTROL SLEEVE 5.125"	1	
9	43215	CONTROL STUD	1	ANTI-SEEZ & TORQUE TO 90IN-LB
10	51420	CONTROL STEM, 5.125"	1	
11	51415	REAR ANVIL, 5.125"	1	ANTI-SEEZ & HAND TIGHT TO BACK OF BODY
12	51417	SPACER, SPLIT 5.125"	2	
13	51408	ISOLATOR, 5.125"	1	ANTI-SEEZ ID & OD
14	51416	TAILCONE, 5.125"	1	
15	30221	TAILBOLT	8	ANTI-SEEZ & TORQUE TO 35FT-LB
16	51418	SERVICE WIHIP ASSY	1	TORQUE TO 200FT-LB
17	30260	SOCKET, 3/8" 12-POINT	1	FOR ITEM 15 - NOT SHOWN
18	9517	HEX DRIVER, 1/4"	1	FOR ITEM 9 - NOT SHOWN
19	80288	LIFTING STRAP, 5 1/8-12	2	NOT SHOWN
20	2114	DECAL, SMALL TOOL	1	NOT SHOWN
21	2115	DECAL, HAMMERHEAD 12" RED	1	NOT SHOWN
22	923-1877	DECAL, PATENTS	1	NOT SHOWN

924-0051 REV D

5.125" (130 mm) PP DF, PN 51422

HAMMERHEAD®

Thank you for buying and using Genuine HammerHead
Trenchless Equipment, parts and accessories.